

SINCHOLD Welded Base Fixing

SINCHOLD 9120/15/38

Adjustable crane rail clip is designed to fix heavy rails in the most arduous applications. It can withstand a horizontal force from the rail of **120kN(12.2 tonnes)**. Its low profile allows it to be used with cranes that are fitted with guide rollers.

SPECIFICATIONS :

MAX SIDE LOAD **120kN**

15 mm HORIZONTAL RAIL ADJUSTMENT

DIMENSIONS (mm):





REF NO.	X	Y	Y	Z	WEIGHT kg
		FULL NUT	THIN NUT		
9120/15/38	38	51	46	30	1.52
S (rubber)	RAIL WITH PAD PLAN			14mm	
H (rubber)	RAIL WITHOUT PAD PLAN			21mm	



FEATURES

- The proven design has been used successfully for many years throughout the world.
- The clip is welded to the rail support. No access is required from below.
- The two main parts are locked together on tightening the grade 8.8 bolt.
- The clip has a self-tightening mechanism.
- A special vulcanized rubber block applies a controlled force to the rail.

COMPONENTS

- ① 
 - ② 
 - ③ 
 - ④ 
 - ⑤ 
1. Flange nut
2. Forging steel clip
3. Vulcanized rubber block
4. Weldable base
5. M20 Captive bolt

1: RAIL WITH PAD

2: RAIL WITHOUT PAD

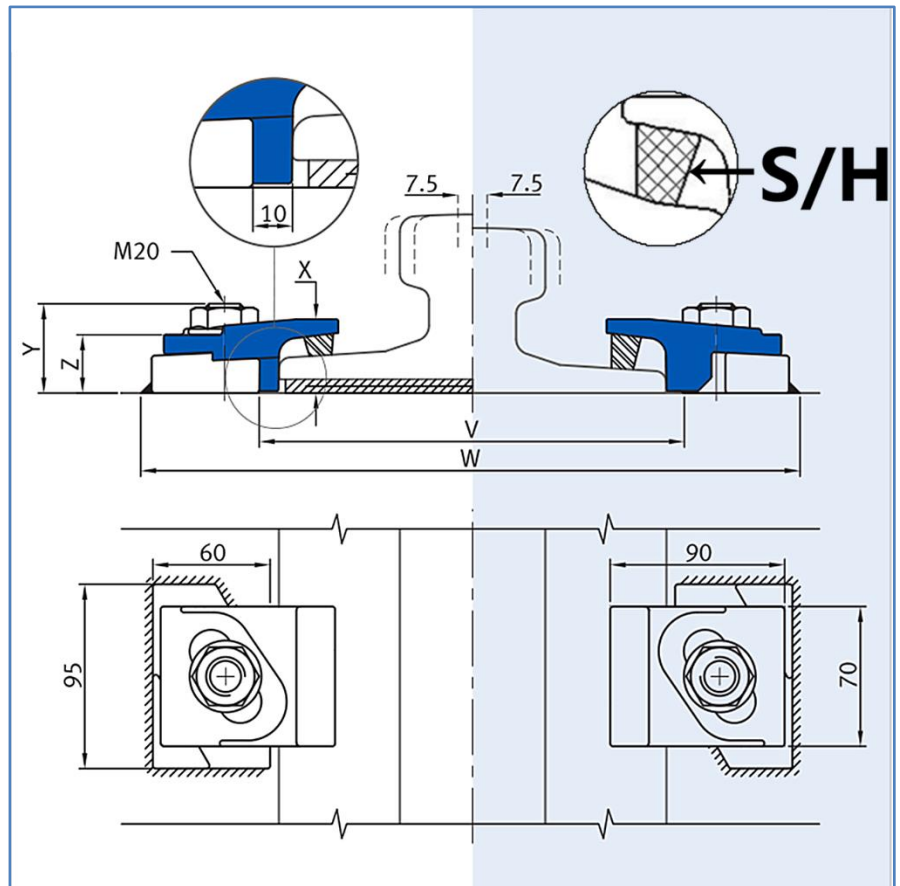

Minimum assembly width - $W = \text{Rail width (F)} + 156\text{mm}$

$V = \text{Rail width (F)} + 20\text{mm}$

SINCHOLD

9120/15/38



SINCHOLD Welded Base Fixing

	F mm	C mm	A mm	RAIL WEIGHT (kg/m)	1. CLIP REFERENCE FOR RAIL WITH PAD	2. CLIP REFERENCE FOR RAIL WITHOUT PAD
P 50	132	70	152	50	9120/15/38 (S)	9120/15/38 (H)
QU 70	120	70	120	52.8	9120/15/38 (S)	9120/15/38 (H)
QU 80	130	80	130	63.69	9120/15/38 (S)	9120/15/38 (H)
QU 100	150	100	150	89	9120/15/38 (S)	9120/15/38 (H)
QU 120	170	120	170	118.5	9120/15/38 (S)	9120/15/38 (H)
A 100	200	100	95	74.3	9120/15/38 (S)	9120/15/38 (H)
A 120	220	120	105	100	9120/15/38 (S)	9120/15/38 (H)
A 150	220	150	150	150.3	9120/15/38 (S)	9120/15/38 (H)
ISCR 100	150	102	150	89	9120/15/38 (S)	9120/15/38 (H)
ISCR 120	170	120	170	118.5	9120/15/38 (S)	9120/15/38 (H)
GCR 183	280	75	120	183.06	9120/15/38 (S)	9120/15/38 (H)
CR 73	140	100	135	73.3	9120/15/38 (S)	9120/15/38 (H)
CR 100	155	120	150	100.2	9120/15/38 (S)	9120/15/38 (H)
JIS 50 N	127	64	153	50.4	9120/15/38 (S)	9120/15/38 (H)
JIS 60	145	64	174	60.8	9120/15/38 (S)	9120/15/38 (H)
S 41	125	67	138	41.4	9120/15/38 (S)	9120/15/38 (H)
S 49	125	67	149	49.43	9120/15/38 (S)	9120/15/38 (H)
MRS 67 (135CR)	132	79	146	67	9120/15/38 (S)	9120/15/38 (H)
MRS 86	165	102	102	85.5	9120/15/38 (S)	9120/15/38 (H)
MRS 87 B	152	102	152	86.8	9120/15/38 (S)	9120/15/38 (H)
68 kg AS	152	73	186	67.6	9120/15/38 (S)	9120/15/38 (H)

This clip can be used for a wider selection of rails than illustrated. Please contact SINCHOLD for the full range of possible rails. All rails can be fastened with bolted or welded base clips. SINCHOLD may change or improve their products and also alter specifications without notice.

INSTALLATION INSTRUCTIONS:

Weld all round the clip base, except the side closest and parallel to the rail, with a 5mm throat thickness fillet weld, using low hydrogen electrodes. Recommended electrodes AWS E7018 or E7028. Clip base is made from weldable grade steel. If a continuous weld around the clip base is required, this is possible. Please consult SINCHOLD for guidance.

TIGHTENING TORQUE 350Nm

Please contact SINCHOLD, for full installation instructions.

WELD DETAIL:

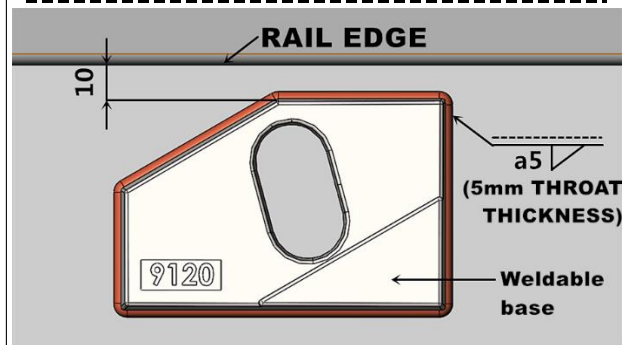

SINCHOLD Port Engineering Co.,Ltd

Tel: 0086-510-83768896 Fax: 0086-510-83768826

E-mail: sales@sinchold.com

Add: No.82 Dongzhuang Industrial Park, Yanqiao Street,
Huishan District, Wuxi City, Jiangsu Province, P.R.China



SINCHOLD 9120/15/38